

SGL-F型

— 高刚性短型 —

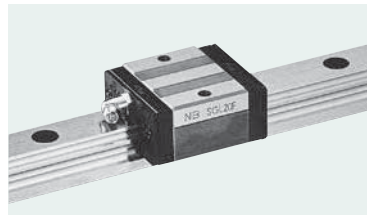

公称型号构成

例) **SGL 15 F B 2 T1 - 589 D P / W2 FS LB F J - KGL**

规格	尺寸	滑块形状	带防尘罩 (参照P.A-18)	带专用盖	低温黑铬处理	带纤维纸板	轴数记号*	精度等级
SGL: 标准规格		密封环 (参照P.A-14)					无记载: 1轴	无记载: 标准
SGLS: 耐腐蚀规格		无记载: 有侧面密封环					W2: 2轴	H: 高级
		B: 有侧面密封环+底面密封环					W3: 3轴	P: 精密级
		BW: 双面密封环+底面密封环						
		BS: B+刮刀						
		BR: B+反向密封环						
		BWS: BW+刮刀						
		1轴所带滑块个数						
		予压标记(参照P.A-52)						
		无记载: 标准						
		T1: 轻予压						
		T2: 中予压						
		轨道全长						
		轨道安装孔的种类 (D型只对应15、30号导轨)						

润滑脂记号 (参照润滑脂P.技-39)
 无记载: 标准润滑脂
 KGL: 锂系低发尘润滑脂
 KGU: 尿素系低发尘润滑脂
 KGF: 耐微磨损损润滑脂

* 轴数记号不表示订货时的轴数。

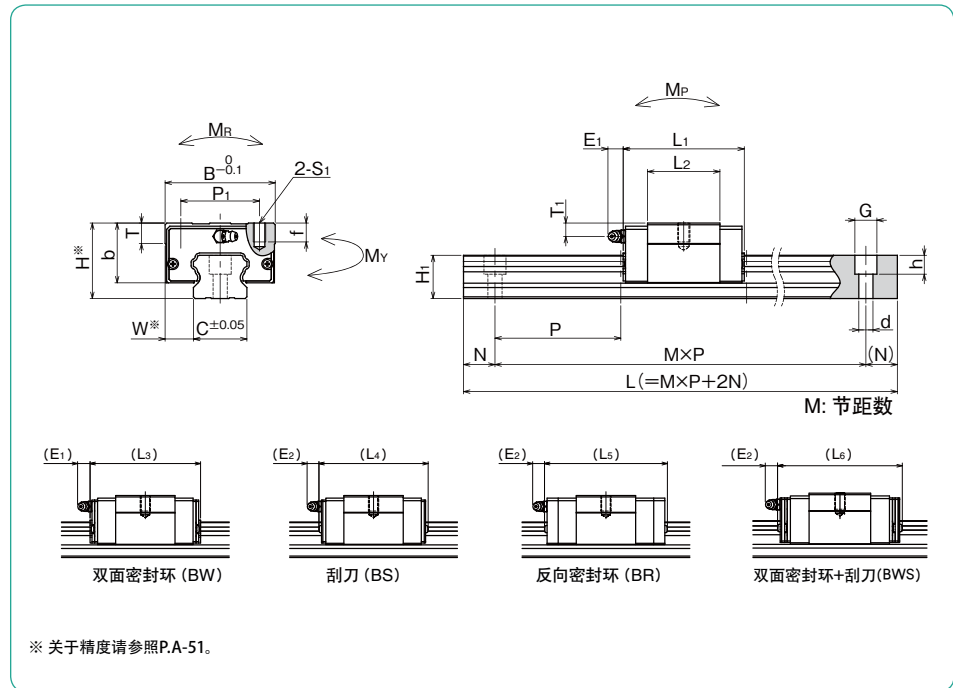

公称型号		组装尺寸		滑块尺寸												
标准规格	耐腐蚀规格	H	W	B	L1	L2	L3	L4	L5	L6	P1	S1	f	T	b	E1
		mm	mm	mm	mm	mm	mm	mm	mm	mm	mm	mm	mm	mm	mm	mm
SGL15F	SGLS15F	24	9.5	34	40.7	22.7	46.9	47.3	54.3	53.5	26	M4	7	6	19.5	6
SGL15F-D	SGLS15F-D															
SGL20F	SGLS20F	28	11	42	47.9	29.5	54.1	54.5	65.5	60.7	32	M5	8	7.5	22	12
SGL25F	SGLS25F	33	12.5	48	58.7	37.7	65.1	65.9	76.9	72.1	35	M6	9	8	26	
SGL30F	—	42	16	60	68	40	76.6	75.6	86.2	84.2	40	M8	12	9	32.5	
SGL30F-D	—															
SGL35F	—	48	18	70	77	46	85.6	84.6	95.2	93.2	50			13	38	

公称型号		标准轨道长度 L														
标准规格	耐腐蚀规格	mm														
SGL15	SGLS15	160	220	280	340	400	460	520	580	640	700	760	820	880	940	1,000
SGL20	SGLS20	220	280	340	400	460	520	580	640	700	760	820	880	940	1,000	1,120
SGL25	SGLS25	220	280	340	400	460	520	580	640	700	760	820	880	940	1,000	1,120
SGL30	—	280	360	440	520	600	680	760	840	920	1,000	1,080	1,160	1,240	1,320	1,400
SGL35	—	280	360	440	520	600	680	760	840	920	1,000	1,080	1,160	1,240	1,320	1,400

超过最大长度的产品也可以通过连接轨道进行对应。详细情况请向NB咨询。

E2	T1	注油嘴	导轨尺寸				基本额定负荷		静态允许力矩			质量			
			H1	C	d×G×h	N	P	动 C	静 Co	MP2	MY2	MR	滑块	导轨	尺寸
mm	mm		mm	mm	mm	mm	mm	kN	kN	N·m	N·m	N·m	kg	kg/m	mm
5.4	5	镶入式注油嘴	13.5	15	3.5×6×4.5	20	60	7.29	9.45	36.7	36.7	73.9	0.1	1.3	15
					4.5×7.5×5.3					252	252				
11	6	B-M6F	16	20	6×9.5×8.5	20	80	11.9	14.8	71.9	71.9	159	0.2	2.1	20
					447					447					
	6.5		20	23	7×11×9	20	80	17.0	21.1	123	123	254	0.3	3.0	25
										751	751				
9	24	28	7×11×9	20	80	23.0	28.7	195	195	417	0.5	4.6	30		
								1,260	1,260						
8.5	27.5	34	9×14×12	20	80	32.0	37.8	293	293	693	0.8	6.2	35		
								1,870	1,870						

允许力矩MP2、MY2为两个滑块紧靠状态下的值。1kN=102kgf 1N·m=0.102kgf·m

1,120	1,240	1,360	1,480	最大长度	
				标准规格	耐腐蚀规格
1,120	1,240	1,360	1,480	2,000	1,480
1,240	1,360	1,480	1,600	3,000	1,480
1,240	1,360	1,480	1,600	3,000	1,480
1,480	1,640	1,720	1,800	3,000	—
1,480	1,640	1,720	1,800	3,000	—